

SPECIAL MEETING
OCTOBER 16, 2017

Be it remembered that on this the 16th day of October A.D. 2017, there came on to be held a Special meeting of the Commissioners' Court, and the Court having convened in Special session at the usual meeting place thereof at the Courthouse in Levelland, Texas, with the following members present to-wit:

Sharla Baldrige	County Judge
Curtis D. Thrash	Commissioner Precinct No. 1
Larry Carter	Commissioner Precinct No. 2
J. L. "Whitey" Barnett	Commissioner Precinct No. 3
Thomas R "Tommy" Clevenger	Commissioner Precinct No. 4

Irene Gumula, County Clerk, and Ex-Officio Clerk of Commissioners' Court when the following proceedings were had, to-wit:

Motion by Commissioner Barnett, seconded by Commissioner Thrash, 4 Votes Yes, 0 Votes No, that the Minutes of a Regular meeting of the Commissioners' Court, held on October 2, 2017, A. D., be approved and stand as read.

Motion by Commissioner Carter, seconded by Commissioner Clevenger, 4 Votes Yes, 0 Votes No, that all monthly claims and bills, submitted to the Court, and dated through October 16, A. D. 2017, be approved and stand as read.

Hear update from Texas A & M AgriLife Extension agents. Discussion only.

Hear update from Hockley County 4-H. Discussion only.

Motion by Commissioner Clevenger, seconded by Commissioner Thrash, 4 Votes Yes, 0 Votes No, that Commissioners' Court approve the 2018 Hockley County Resolution Indigent Defense Grant Program, as per Resolution recorded below.

**2018 Hockley County Resolution
Indigent Defense Grant Program**

WHEREAS, under the provisions of the Texas Government Code Section 79.037 and Texas Administrative Code Chapter 173, counties are eligible to receive grants from the Texas Indigent Defense Commission to provide improvements in indigent defense services in the county; and

WHEREAS, this grant program will assist the county in the implementation and the improvement of the indigent criminal defense services in this county; and

WHEREAS, Hockley County Commissioners Court has agreed that in the event of loss or misuse of the funds, Hockley County Commissioners assures that the funds will be returned in full to the Texas Indigent Defense Commission.

NOW THEREFORE, BE IT RESOLVED and ordered that the County Judge of this county is designated as the Authorized Official to apply for, accept, decline, modify, or cancel the grant application for the Indigent Defense Formula Grant Program and all other necessary documents to accept said grant; and

BE IT FURTHER RESOLVED that the County Auditor is designated as the Financial Officer for this grant.

Adopted this 11th day of October, 2017.

Sharla Baldrige

Sharla Baldrige
County Judge

Attest:

Drene Kumala by Janie Salazar
County Clerk



Motion Commissioner Carter, seconded by Commissioner Barnett, 4 Votes Yes, 0 Votes No, that Commissioners' Court grant permission and authority to Centurion Pipeline L.P. on Wildcat Road in Precinct 2, to lay, construct, operate and maintain (1)-6" pipeline transporting Condensate under and across certain county roads, situated in Commissioners' Precinct No. 2, Hockley County, Texas, as set forth in the below recorded Petition, Exhibit and Order of the Court.

RECORD, PETITION, EXHIBIT AND ORDER OF THE COURT

BEFORE THE HONORABLE BOARD OF COUNTY COMMISSIONERS
HOCKLEY COUNTY, TEXAS

IN THE MATTER OF THE APPLICATION OF Centurion Pipeline L.P. FOR
AUTHORITY TO USE A PART OF THE PUBLIC ROADS OF HOCKLEY COUNTY, TEXAS

PETITION

Comes now, the Petitioner, Centurion Pipeline L.P., and petitions this Honorable Board for the right and authority to lay, construct, operate and maintain 10-6" pipelines under and across certain county roads situated in Hockley County, Texas, which said pipelines are to be used for the purpose of transporting Condensate from the Petitioner's sources of supply to Petitioner's markets.

The location of the points at which Petitioner wishes to undercross said county roads with said pipelines and the general specifications are more particularly described on a map marked Exhibit "A" and general specifications marked Exhibit "B", all of which are attached hereto and made a part of this application. Petitioner represents and states that if granted the authority herein requested, it will conform with and abide by the rules of all persons and bodies having jurisdiction and by the following conditions:

1. The Petitioner shall, in constructing said pipelines undercrossings cause the very minimum of inconvenience and obstruction of public travel along said roads, and, further, shall operate and maintain said pipelines undercrossings in a manner so as not to inconvenience, endanger or obstruct public travel along said roads.
2. Upon the completion of each pipelines undercrossing constructed hereunder Petitioner shall immediately backfill, re-construct and replace the portions of the roads across which said pipelines are laid and constructed so that such roads shall be in equally as good a condition as prior to such construction.
3. So long as said pipelines are maintained and operated under said roads Petitioner shall be responsible for doing any work which, due to the existence of said pipelines undercrossings, needs to be done on said roads at the location thereof, all in order to maintain said roads, at such points, in a condition equal to other portions of said county roads.
4. Should Petitioner remove said pipelines from any of said roads, it will replace and recondition the road concerned, at the location of said removal, in substantially the same condition as it was prior to such removal, all liability of Petitioner for the maintenance and reconditioning of such roads shall cease as soon after such removal as the COUNTY OF HOCKLEY has approved the maintenance and reconditioning work done by Petitioner.
5. Petitioner agrees that if at any time the County of Hockley shall deem it necessary to make any improvements or changes on all of or any part of the right of way of the county roads which affect the Utility as located under this order, then and in such event, the Petitioner or his Assignee shall make such reasonable changes of its facilities located within such right of way as may be deemed necessary, such work to be done without cost to Hockley County, Texas.
6. The construction or laying of said pipelines by Petitioner hereunder shall be considered and shall constitute and acceptance of this order and of all of the terms and conditions herein set forth.
7. Petitioner agrees that if at any time the County of Hockley deems it necessary that these crossings be encased in accordance with the then existing State Highway specifications, Petitioner agrees to do so at its own expense.

Wherefore, your Petitioner respectfully prays that your Honorable Board enter and order herein authorizing Petitioner to use and occupy the portions of the roads in Hockley County, Texas, more particularly herein above set out and described and at the locations shown and set out in said Exhibits "A" and "B" attached to this application.

DATED this 27th day of September, 2017.

BY 

September 27, 2017

Larry Carter
802 Houston Street, Suite 101
Levelland, TX 79336

Dear Mr. Carter,

Centurion Pipeline L.P. ("Centurion") is applying for a permit to cross Wildcat Road in Hockley County, Texas, with a 6" steel pipeline. Centurion will be paralleling an existing pipeline with 10' separation between the existing and proposed new pipeline. The existing pipeline crosses Wildcat Road at less than a 90 degree angle and Centurion would like to continue paralleling the existing line and cross Wildcat Road via boring method at the same angle as the existing pipeline.

Respectfully,



Ryan McReynolds
Sr. Landman/ROW Agent
Office: 713-513-6653

 **Centurion Pipeline L.P.**



MGP TO MALLET CONNECTION
PIPELINE

AFE NO. 1207769
HOCKLEY COUNTY, TEXAS
ISSUED FOR CONSTRUCTION
DATE 08-22-2017

CPL-056T-14-001

Centurion Pipeline L.P.		Facility Name: SLAUGHTER GAS PLANT TO MALLET STATION PIPELINE	Rev. 0	Description: ISSUED FOR CONSTRUCTION - (MGP TO MALLET CONN.)	Date: 08/22/17	Rev. by: D	Checked by: Jat	Approved by: H. J. H.
Drawing #	CPL-056T-14-002	Rev. 0	Project Name: MGP to Mallet Connection	Project No.: 1207769				
Title	MASTER DRAWING INDEX		Drawn: DQ	Date: 06/28/17				
			Check: JN	Date: 06/28/17				
			Appr: DH	Date: 06/28/17				

FORM: CP-EN-FRM-000-0048 (REV 3)

CONSTRUCTION DRAWINGS				DRAWING NO.	REV	TITLE	ISSUE DATE
CPL-056T-14-001	0	COVER SHEET	08/22/17				
CPL-056T-14-002	0	MASTER DRAWING INDEX	08/22/17				
ALIGNMENT SHEETS							
CPL-056-06T-001	0	ALIGNMENT SHEET - FR. STN. 0+00 TO STN. 116+00	08/22/17				
CPL-056-06T-002	0	ALIGNMENT SHEET - FR. STN. 116+00 TO STN. 223+40	08/22/17				
TYPICAL DETAILS							
CPL-056T-11-001	0	DETAIL - A - 75' PIPELINE ROW RIGHT - WORKING SIDE	08/22/17				
CPL-056T-11-002	0	DETAIL - B&C - 75' PIPELINE ROW RIGHT - WORKING SIDE	08/22/17				
CPL-056T-11-003	0	ROAD R/W CROSSING PIPELINE - TYP. OPEN CUT	08/22/17				
CPL-056T-11-004	0	ROAD CROSSING TYPICAL BORE	08/22/17				
CPL-056T-11-005	0	FOREIGN PIPELINE OR UTILITY CROSSING	08/22/17				
CPL-056T-11-006	0	DETAIL - D - 100' PIPELINE ROW RIGHT - WORKING SIDE	08/22/17				
CPL-056T-11-007	0	BORE HOLE DETAIL - WILD CAT ROAD & HWY 301 CROSSING	08/22/17				
CPL-000-0518	0	FOREIGN PIPELINE OR UTILITY CROSSING	INFO				
CPL-000-556	0	CATHODIC PROTECTION STD. SINGLE POINT TEST STN. TYPE 1	INFO				
CPL-000-557	0	CATHODIC PROTECTION FOREIGN PIPELINE CROSSING TEST STN. TYPE 2	INFO				
PROPERTY SKETCH	B	PROPOSED 50' P/L EASEMENT	INFO				

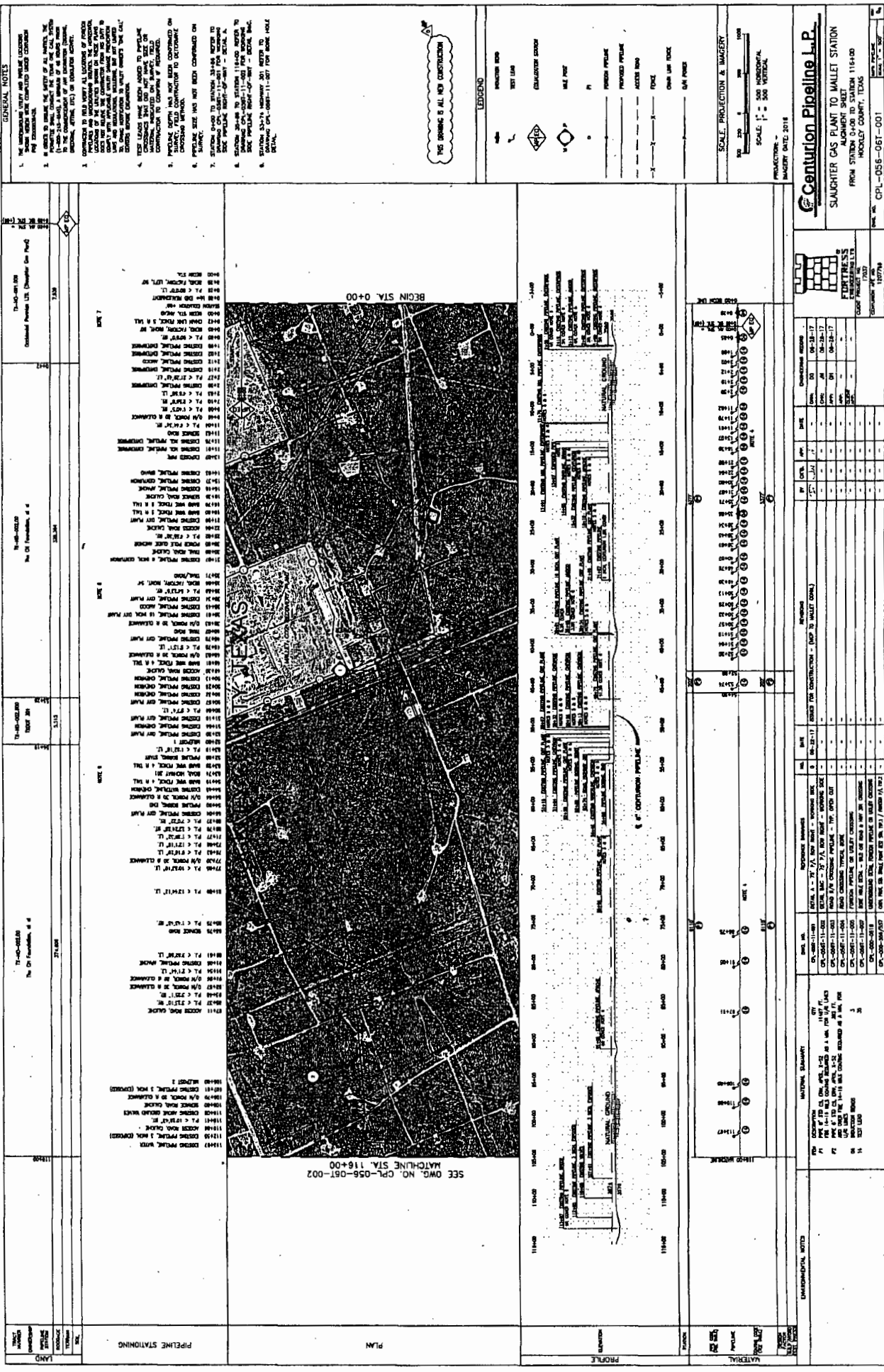

GENERAL NOTES

1. THE INFORMATION CONTAINED HEREIN IS FOR THE USE OF THE CONTRACTOR AND IS NOT TO BE USED FOR ANY OTHER PURPOSE.
2. THE CONTRACTOR SHALL BE RESPONSIBLE FOR OBTAINING ALL NECESSARY PERMITS AND APPROVALS FROM THE APPROPRIATE AGENCIES.
3. THE CONTRACTOR SHALL BE RESPONSIBLE FOR PROTECTING ALL EXISTING UTILITIES AND STRUCTURES.
4. THE CONTRACTOR SHALL BE RESPONSIBLE FOR MAINTAINING ACCESS TO ALL ADJACENT PROPERTIES.
5. THE CONTRACTOR SHALL BE RESPONSIBLE FOR RESTORING ALL AREAS TO ORIGINAL OR BETTER CONDITION.
6. THE CONTRACTOR SHALL BE RESPONSIBLE FOR THE PROTECTION OF ALL ENVIRONMENTAL FEATURES.
7. THE CONTRACTOR SHALL BE RESPONSIBLE FOR THE PROTECTION OF ALL HISTORIC AND CULTURAL RESOURCES.
8. THE CONTRACTOR SHALL BE RESPONSIBLE FOR THE PROTECTION OF ALL ARCHAEOLOGICAL REMAINS.
9. THE CONTRACTOR SHALL BE RESPONSIBLE FOR THE PROTECTION OF ALL ANTHROPOLOGICAL REMAINS.
10. THE CONTRACTOR SHALL BE RESPONSIBLE FOR THE PROTECTION OF ALL PALEONTOLOGICAL REMAINS.

LEGEND

- PROPOSED PIPELINE
- EXISTING PIPELINE
- PROPOSED ACCESS ROAD
- EXISTING ACCESS ROAD
- PROPOSED FENCE
- EXISTING FENCE
- PROPOSED CHAIN LINK FENCE
- EXISTING CHAIN LINK FENCE
- PROPOSED CONCRETE CURB
- EXISTING CONCRETE CURB
- PROPOSED ASPHALT DRIVE
- EXISTING ASPHALT DRIVE
- PROPOSED GRAVEL DRIVE
- EXISTING GRAVEL DRIVE
- PROPOSED DIRT DRIVE
- EXISTING DIRT DRIVE
- PROPOSED EASEMENT
- EXISTING EASEMENT
- PROPOSED RIGHT-OF-WAY
- EXISTING RIGHT-OF-WAY
- PROPOSED UTILITY
- EXISTING UTILITY
- PROPOSED STRUCTURE
- EXISTING STRUCTURE
- PROPOSED ROAD
- EXISTING ROAD
- PROPOSED RAILROAD
- EXISTING RAILROAD
- PROPOSED AIRPORT
- EXISTING AIRPORT
- PROPOSED CANAL
- EXISTING CANAL
- PROPOSED DAM
- EXISTING DAM
- PROPOSED LEVEE
- EXISTING LEVEE
- PROPOSED DIKE
- EXISTING DIKE
- PROPOSED TOWER
- EXISTING TOWER
- PROPOSED LIGHT
- EXISTING LIGHT
- PROPOSED SIGN
- EXISTING SIGN
- PROPOSED MARKER
- EXISTING MARKER
- PROPOSED BENCHMARK
- EXISTING BENCHMARK
- PROPOSED CONTROL POINT
- EXISTING CONTROL POINT
- PROPOSED ADJUSTED POINT
- EXISTING ADJUSTED POINT
- PROPOSED UNADJUSTED POINT
- EXISTING UNADJUSTED POINT
- PROPOSED POINT
- EXISTING POINT
- PROPOSED LINE
- EXISTING LINE
- PROPOSED CURVE
- EXISTING CURVE
- PROPOSED SLOPE
- EXISTING SLOPE
- PROPOSED ELEVATION
- EXISTING ELEVATION
- PROPOSED DISTANCE
- EXISTING DISTANCE
- PROPOSED AREA
- EXISTING AREA
- PROPOSED VOLUME
- EXISTING VOLUME
- PROPOSED PERCENT
- EXISTING PERCENT
- PROPOSED RATIO
- EXISTING RATIO
- PROPOSED FRACTION
- EXISTING FRACTION
- PROPOSED DECIMAL
- EXISTING DECIMAL
- PROPOSED INTEGER
- EXISTING INTEGER
- PROPOSED REAL
- EXISTING REAL
- PROPOSED COMPLEX
- EXISTING COMPLEX
- PROPOSED VECTOR
- EXISTING VECTOR
- PROPOSED MATRIX
- EXISTING MATRIX
- PROPOSED TENSOR
- EXISTING TENSOR
- PROPOSED SCALAR
- EXISTING SCALAR
- PROPOSED VECTOR SPACE
- EXISTING VECTOR SPACE
- PROPOSED TENSOR SPACE
- EXISTING TENSOR SPACE
- PROPOSED SCALAR SPACE
- EXISTING SCALAR SPACE
- PROPOSED VECTOR SPACE
- EXISTING VECTOR SPACE
- PROPOSED TENSOR SPACE
- EXISTING TENSOR SPACE
- PROPOSED SCALAR SPACE
- EXISTING SCALAR SPACE

SCALE, PROJECTION & IMAGERY

SCALE: 1" = 500' HORIZONTAL
 SCALE: 1" = 500' VERTICAL

PROJECTION: UTM
 DATUM: NAD 83

PRODUCTION INFORMATION

PROJECT: Slaughter Gas Plant to Wallet Station
 SHEET: ALIGNMENT SHEET
 FROM STATION 0+00 TO STATION 116+00
 PROJECT COUNTY: TARRANT
 DRAWING NO.: CPL-056-06T-001
 DATE: 11/17/2016

NO.	DESCRIPTION	DATE	BY	CHKD.	APP.
1	DESIGNED	11-17-16	J. W. WILSON	J. W. WILSON	J. W. WILSON
2	CHECKED	11-17-16	J. W. WILSON	J. W. WILSON	J. W. WILSON
3	APPROVED	11-17-16	J. W. WILSON	J. W. WILSON	J. W. WILSON

NO.	DESCRIPTION	DATE	BY	CHKD.	APP.
1	DESIGNED	11-17-16	J. W. WILSON	J. W. WILSON	J. W. WILSON
2	CHECKED	11-17-16	J. W. WILSON	J. W. WILSON	J. W. WILSON
3	APPROVED	11-17-16	J. W. WILSON	J. W. WILSON	J. W. WILSON

NO.	DESCRIPTION	DATE	BY	CHKD.	APP.
1	DESIGNED	11-17-16	J. W. WILSON	J. W. WILSON	J. W. WILSON
2	CHECKED	11-17-16	J. W. WILSON	J. W. WILSON	J. W. WILSON
3	APPROVED	11-17-16	J. W. WILSON	J. W. WILSON	J. W. WILSON

NO.	DESCRIPTION	DATE	BY	CHKD.	APP.
1	DESIGNED	11-17-16	J. W. WILSON	J. W. WILSON	J. W. WILSON
2	CHECKED	11-17-16	J. W. WILSON	J. W. WILSON	J. W. WILSON
3	APPROVED	11-17-16	J. W. WILSON	J. W. WILSON	J. W. WILSON

NO.	DESCRIPTION	DATE	BY	CHKD.	APP.
1	DESIGNED	11-17-16	J. W. WILSON	J. W. WILSON	J. W. WILSON
2	CHECKED	11-17-16	J. W. WILSON	J. W. WILSON	J. W. WILSON
3	APPROVED	11-17-16	J. W. WILSON	J. W. WILSON	J. W. WILSON

NO.	DESCRIPTION	DATE	BY	CHKD.	APP.
1	DESIGNED	11-17-16	J. W. WILSON	J. W. WILSON	J. W. WILSON
2	CHECKED	11-17-16	J. W. WILSON	J. W. WILSON	J. W. WILSON
3	APPROVED	11-17-16	J. W. WILSON	J. W. WILSON	J. W. WILSON

NO.	DESCRIPTION	DATE	BY	CHKD.	APP.
1	DESIGNED	11-17-16	J. W. WILSON	J. W. WILSON	J. W. WILSON
2	CHECKED	11-17-16	J. W. WILSON	J. W. WILSON	J. W. WILSON
3	APPROVED	11-17-16	J. W. WILSON	J. W. WILSON	J. W. WILSON

NO.	DESCRIPTION	DATE	BY	CHKD.	APP.
1	DESIGNED	11-17-16	J. W. WILSON	J. W. WILSON	J. W. WILSON
2	CHECKED	11-17-16	J. W. WILSON	J. W. WILSON	J. W. WILSON
3	APPROVED	11-17-16	J. W. WILSON	J. W. WILSON	J. W. WILSON

NO.	DESCRIPTION	DATE	BY	CHKD.	APP.
1	DESIGNED	11-17-16	J. W. WILSON	J. W. WILSON	J. W. WILSON
2	CHECKED	11-17-16	J. W. WILSON	J. W. WILSON	J. W. WILSON
3	APPROVED	11-17-16	J. W. WILSON	J. W. WILSON	J. W. WILSON

NO.	DESCRIPTION	DATE	BY	CHKD.	APP.
1	DESIGNED	11-17-16	J. W. WILSON	J. W. WILSON	J. W. WILSON
2	CHECKED	11-17-16	J. W. WILSON	J. W. WILSON	J. W. WILSON
3	APPROVED	11-17-16	J. W. WILSON	J. W. WILSON	J. W. WILSON

NO.	DESCRIPTION	DATE	BY	CHKD.	APP.
1	DESIGNED	11-17-16	J. W. WILSON	J. W. WILSON	J. W. WILSON
2	CHECKED	11-17-16	J. W. WILSON	J. W. WILSON	J. W. WILSON
3	APPROVED	11-17-16	J. W. WILSON	J. W. WILSON	J. W. WILSON

NO.	DESCRIPTION	DATE	BY	CHKD.	APP.
1	DESIGNED	11-17-16	J. W. WILSON	J. W. WILSON	J. W. WILSON
2	CHECKED	11-17-16	J. W. WILSON	J. W. WILSON	J. W. WILSON
3	APPROVED	11-17-16	J. W. WILSON	J. W. WILSON	J. W. WILSON

NO.	DESCRIPTION	DATE	BY	CHKD.	APP.
1	DESIGNED	11-17-16	J. W. WILSON	J. W. WILSON	J. W. WILSON
2	CHECKED	11-17-16	J. W. WILSON	J. W. WILSON	J. W. WILSON
3	APPROVED	11-17-16	J. W. WILSON	J. W. WILSON	J. W. WILSON

NO.	DESCRIPTION	DATE	BY	CHKD.	APP.
1	DESIGNED	11-17-16	J. W. WILSON	J. W. WILSON	J. W. WILSON
2	CHECKED	11-17-16	J. W. WILSON	J. W. WILSON	J. W. WILSON
3	APPROVED	11-17-16	J. W. WILSON	J. W. WILSON	J. W. WILSON

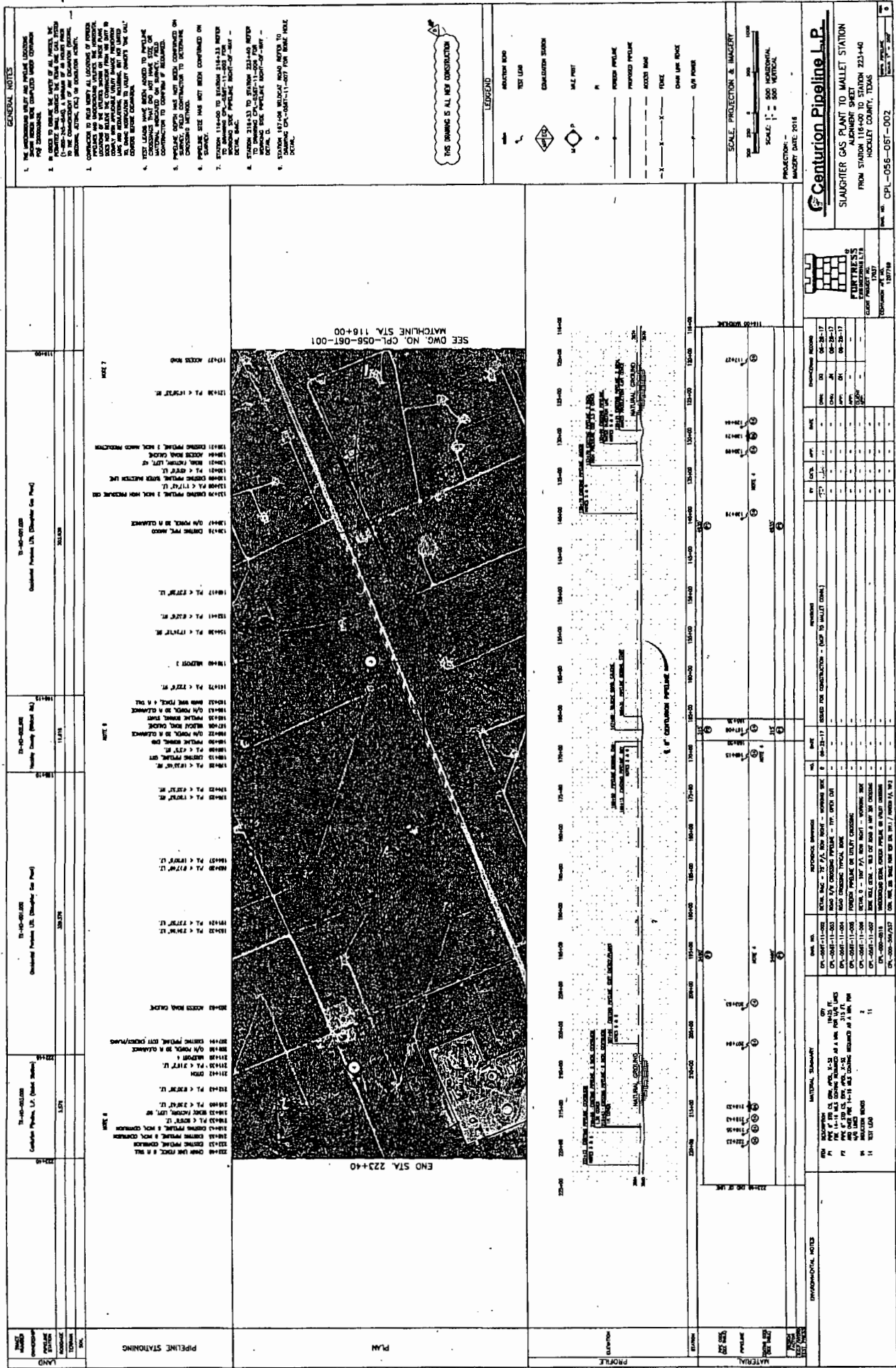

NO.	DESCRIPTION	DATE	BY	CHKD.	APP.
1	DESIGNED	11-17-16	J. W. WILSON	J. W. WILSON	J. W. WILSON
2	CHECKED	11-17-16	J. W. WILSON	J. W. WILSON	J. W. WILSON
3	APPROVED	11-17-16	J. W. WILSON	J. W. WILSON	J. W. WILSON

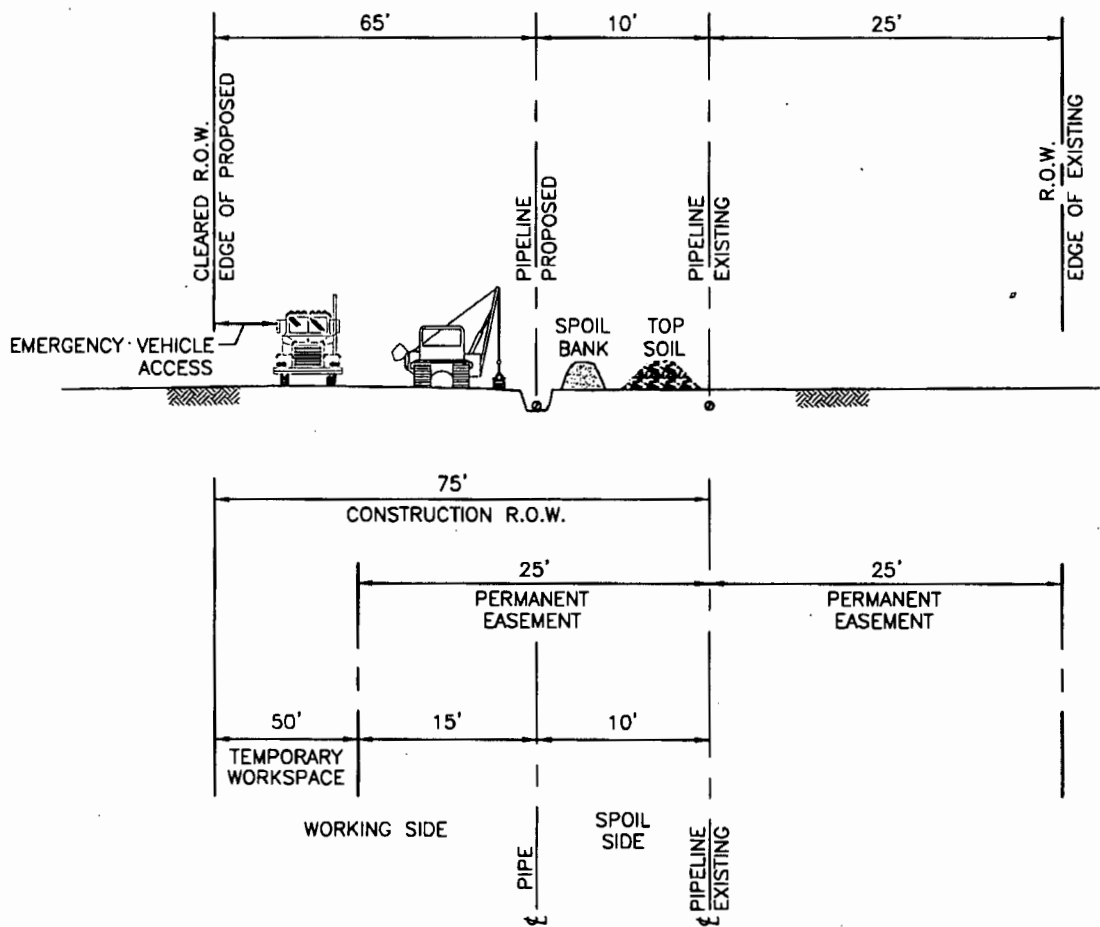



NOTES:

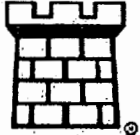

1. CONSTRUCTION RIGHT-OF-WAY WILL TYPICALLY BE 75 FEET WIDE, CONSISTING OF 25 FEET OF PERMANENT EASEMENT AND 50 FEET OF TEMPORARY WORKSPACE. FURTHER, ADDITIONAL TEMPORARY WORKSPACE (ATWS) WILL BE NECESSARY FOR HORIZONTAL DIRECTIONAL DRILL INSTALLATIONS AND AT ROAD, RAIL AND RIVER CROSSINGS AND OTHER SPECIAL CIRCUMSTANCES, AS REQUIRED. CERTAIN SITUATIONS MAY REQUIRE A NARROWER WIDTH.
2. LEAVE GAPS IN SPOIL PILES AT KNOWN DRAINAGE LOCATIONS, UTILIZING PROPERLY INSTALLED BEST MANAGEMENT PRACTICES TO PREVENT SEDIMENTATION. UPLAND SOILS SHALL NOT BE PLACED IN CANALS OR WETLANDS.
3. DITCH LINE TOPSOIL IN ALL JURISDICTIONAL WETLANDS, JURISDICTIONAL CROSSINGS, AND IN ALL AGRICULTURAL AREAS.
4. SEE ALIGNMENT SHEETS FOR ACTUAL ROW CONFIGURATION.

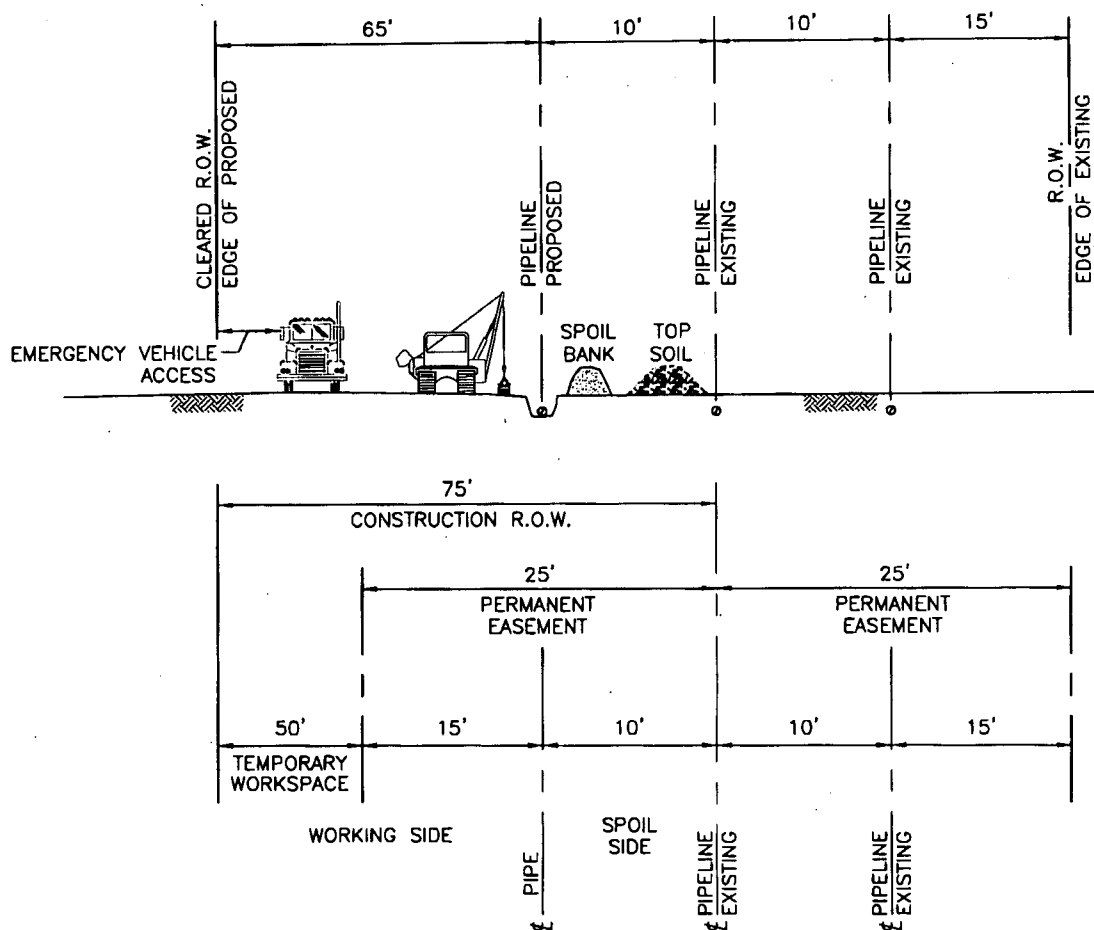
DWG. NO.		REFERENCE DRAWINGS		ENGINEERING RECORD		 FORTRESS ENGINEERING LTD	 Centurion Pipeline L.P.			
PROPERTY SKETCH		PROPOSED 50' PA EASEMENT		DRN:	JBB		06-30-17	DETAIL - A 75' PIPELINE RIGHT-OF-WAY RIGHT - WORKING SIDE		
CLP-056-06T-001		ALIGNMENT SHEET		CHK:	JSN		06-30-17			
				APP:	DH		06-30-17			
				APP:						
				CLIENT APP:						
NO.	DATE	REVISIONS		BY	CHKD	APP.	DATE			
0	08-22-17	IFC - (MGP TO MALLET CONN.)		<i>D</i>	<i>JN</i>	<i>A</i>				
				CLIENT PROJECT NO.		CENTURION AFE NO.		DWG. NO.	DEPT: PIPELINE	REV.
								CPL-056T-11-001	SCALE: NONE	0



NOTES:

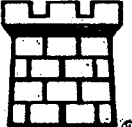

1. CONSTRUCTION RIGHT-OF-WAY WILL TYPICALLY BE 75 FEET WIDE, CONSISTING OF 25 FEET OF PERMANENT EASEMENT AND 50 FEET OF TEMPORARY WORKSPACE. FURTHER, ADDITIONAL TEMPORARY WORKSPACE (ATWS) WILL BE NECESSARY FOR HORIZONTAL DIRECTIONAL DRILL INSTALLATIONS AND AT ROAD, RAIL AND RIVER CROSSINGS AND OTHER SPECIAL CIRCUMSTANCES, AS REQUIRED. CERTAIN SITUATIONS MAY REQUIRE A NARROWER WIDTH.
2. LEAVE GAPS IN SPOIL PILES AT KNOWN DRAINAGE LOCATIONS, UTILIZING PROPERLY INSTALLED BEST MANAGEMENT PRACTICES TO PREVENT SEDIMENTATION. UPLAND SOILS SHALL NOT BE PLACED IN CANALS OR WETLANDS.
3. DITCH LINE TOPSOIL IN ALL JURISDICTIONAL WETLANDS, JURISDICTIONAL CROSSINGS, AND IN ALL AGRICULTURAL AREAS.
4. SEE ALIGNMENT SHEETS FOR ACTUAL ROW CONFIGURATION.

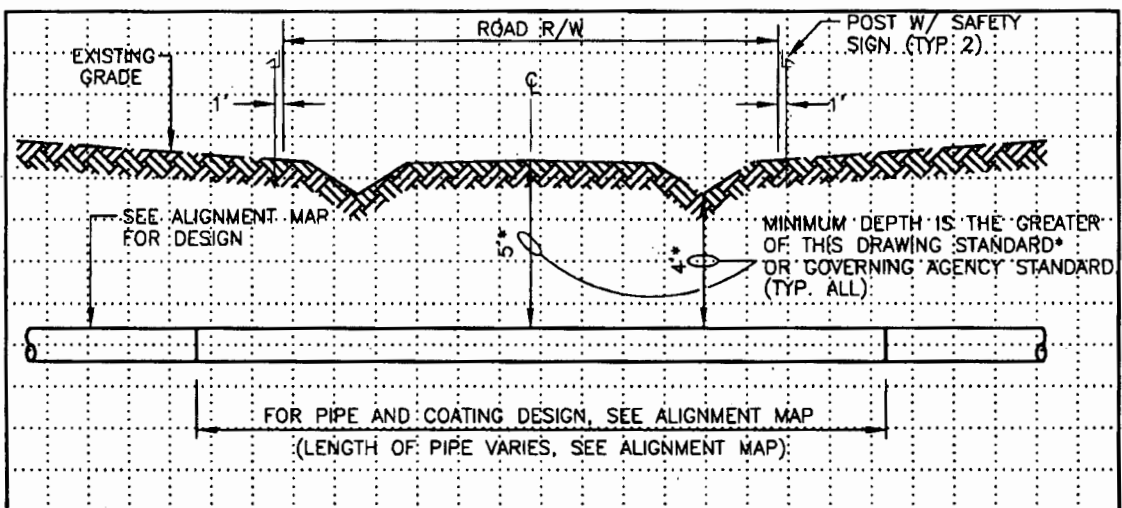
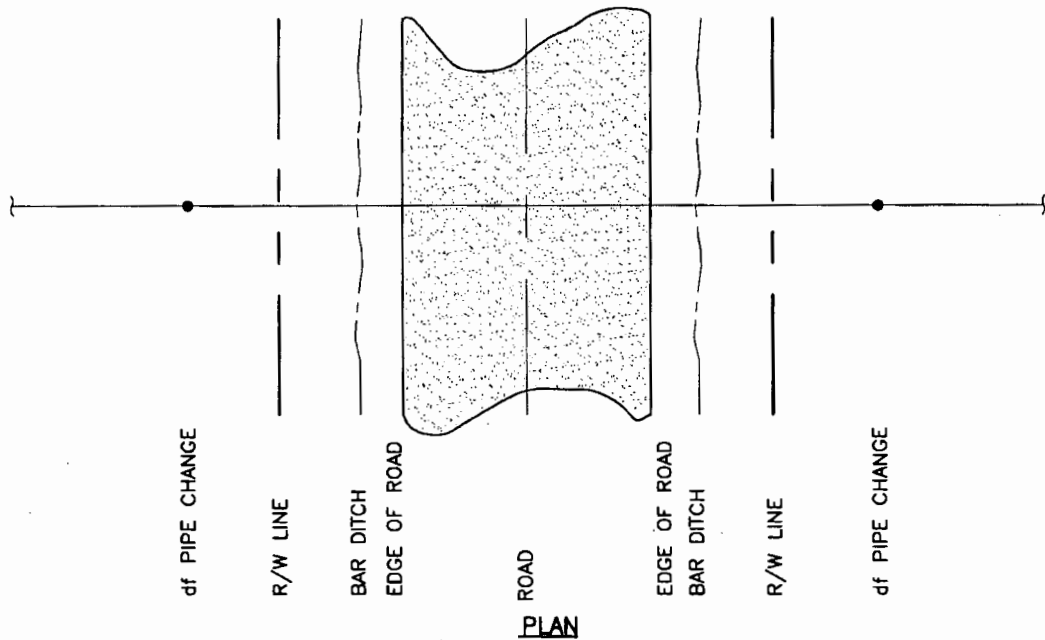
DWG. NO.		REFERENCE DRAWINGS		ENGINEERING RECORD				 FORTRESS ENGINEERING LTD	 Centurion Pipeline L.P.	
PROPERTY SKETCH		PROPOSED 50' PAL EASEMENT		DRN:	JBB	06-30-17	DETAIL - B & C 75' PIPELINE RIGHT-OF-WAY RIGHT - WORKING SIDE			
CPL-056-06T-001		ALIGNMENT SHEET		CHK:	JSN	06-30-17			DWG. NO. CPL-056T-11-002	DEPT: PIPELINE SCALE: NONE
CPL-056-06T-002		ALIGNMENT SHEET		APP:	DH	06-30-17	REV.			
				CLIENT APP:						
NO.	DATE	REVISIONS		BY	CKD.	APP.	DATE			
0	08-22-17	IFC - (MGP TO MALLET CONN.)		JEN	JEN	JH				
				CLIENT PROJECT NO.		CENTURION AFE NO.				

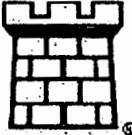

GENERAL NOTES:

1. IF MULTIPLE MINIMUM DEPTH STANDARDS EXIST, ALL MINIMUMS MUST BE MET.
2. PIPELINE INSTALLED UNDER CODE: TITLE 49, PART 195 CFR, of PER RESPECTIVE ALIGNMENT MAP.
3. FOR PIPELINE DESIGN DATA, REFER TO RESPECTIVE ALIGNMENT MAP.

DWG. NO.		REFERENCE DRAWINGS		ENGINEERING RECORD				 FORTRESS ENGINEERING LTD	 Centurion Pipeline L.P.		
CPL-056-06T-001		ALIGNMENT SHEET		DRN:	DQ	07-27-17			DETAIL ROAD R/W CROSSING PIPELINE TYPICAL OPEN CUT HOCKLEY COUNTY, TEXAS		
CPL-056-06T-002		ALIGNMENT SHEET		CHK:	JB	07-27-17					
				APP:	DH	07-27-17					
				APP:				DWG. NO. CPL-056T-11-003			
				CLIENT APP:				DEPT: CIVIL			
NO.	DATE	REVISIONS		BY	CHKD.	APP.	DATE	SCALE: NONE			
0	08-22-17	IFC - (MGP TO MALLET CONN.)						REV. 0			
				CLIENT PROJECT NO. 17037 CENTURION AFE NO. 1207789							

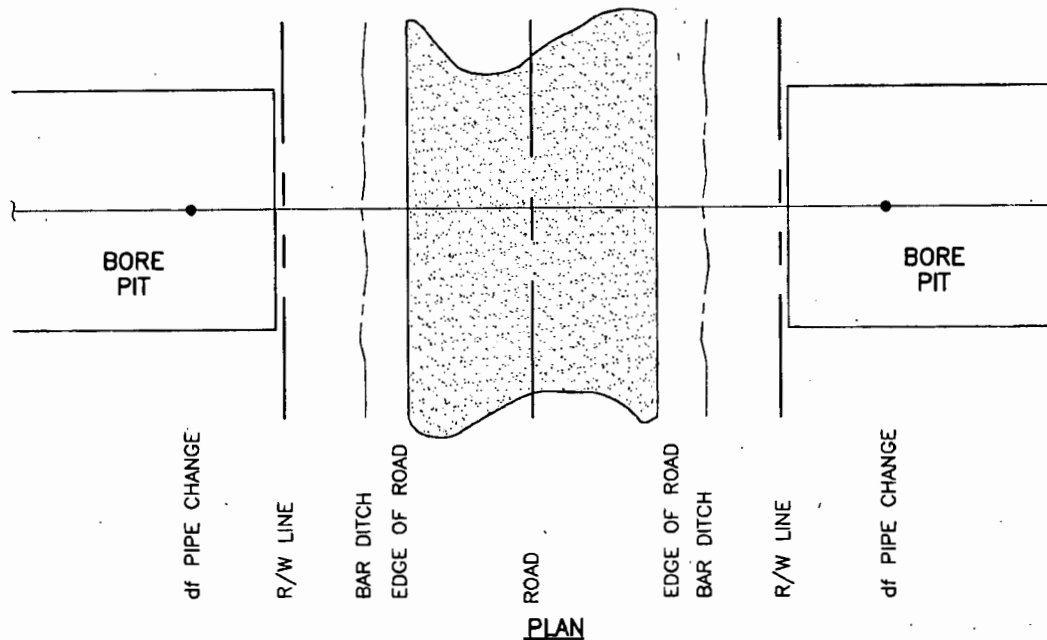

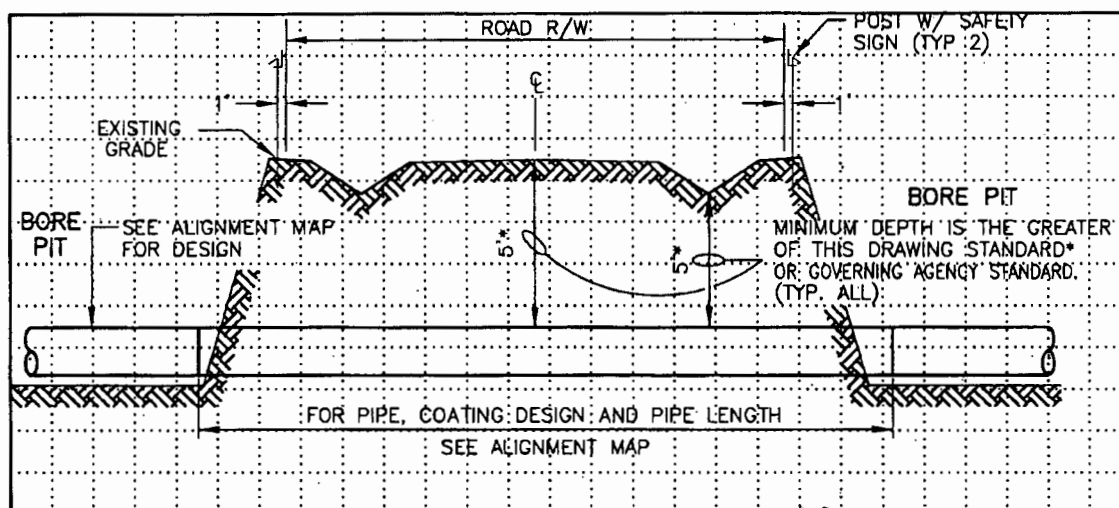

PLAN

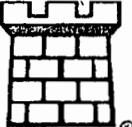

GENERAL NOTES:

1. IF MULTIPLE MINIMUM DEPTH STANDARDS EXIST, ALL MINIMUMS MUST BE MET.
2. PIPELINE INSTALLED UNDER CODE: TITLE 49, PART 195 CFR, *df* PER RESPECTIVE ALIGNMENT MAP.
3. FOR PIPELINE DESIGN DATA, REFER TO RESPECTIVE ALIGNMENT MAP.

DWG. NO.		REFERENCE DRAWINGS		ENGINEERING RECORD				 FORTRESS ENGINEERING LTD	 Centurion Pipeline L.P.		
CPL-056-067-001		ALIGNMENT SHEET		DRN:	DQ	07-27-17			DETAIL ROAD CROSSING TYPICAL BORE HOCKLEY COUNTY, TEXAS		
CPL-056-067-002		ALIGNMENT SHEET		CHK:	JB	07-27-17					
				APP:	DH	07-27-17					
				APP:							
				CLIENT APP:							
NO.	DATE	REVISIONS		BY	CKD.	APP.	DATE				
0	08-22-17	IFC - (MGP TO MALLETT CONN.)		<i>[Signature]</i>	JSH	AI					
				CLIENT PROJECT NO.		17037		DWG. NO.		DEPT: CIVIL	REV.
				CENTURION AFE NO.		1207789		CPL-056T-11-004		SCALE: NONE	0

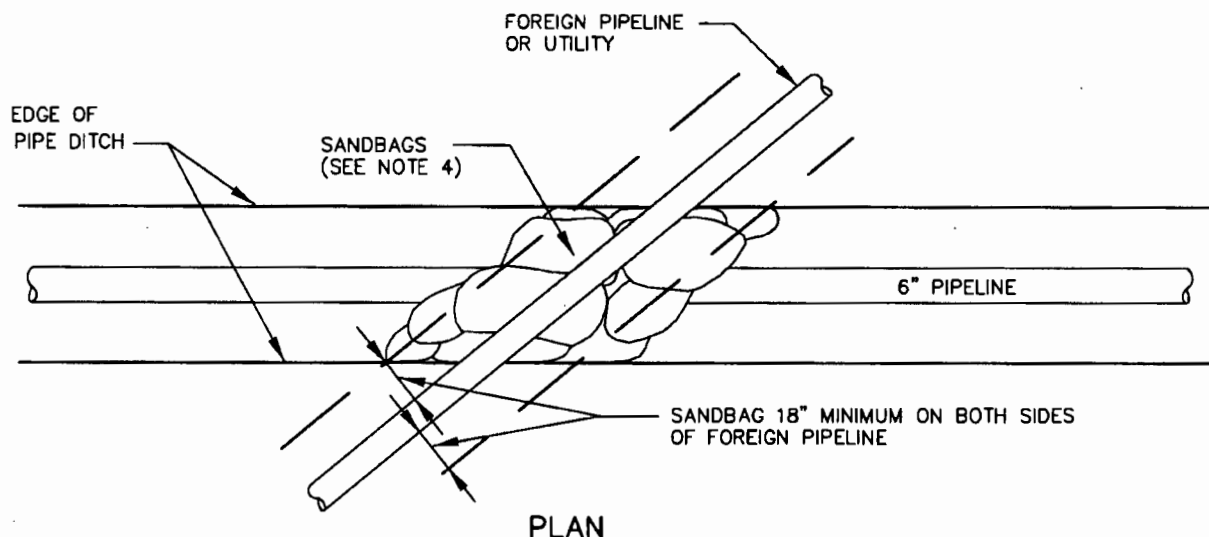

PLAN

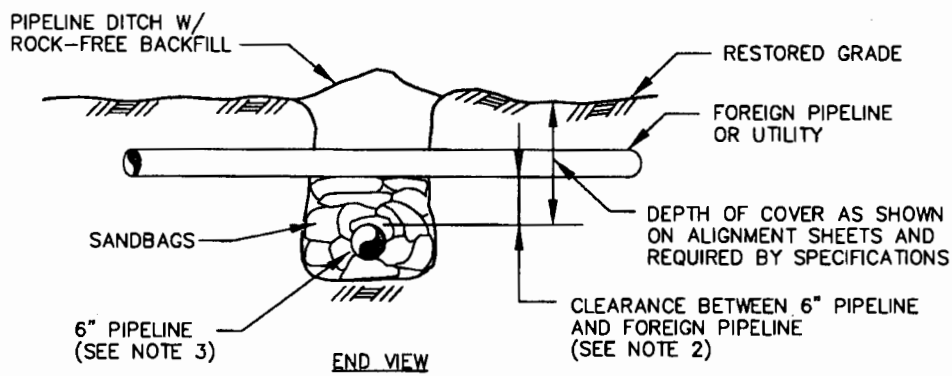



END VIEW

CROSS SECTION

NOTES:

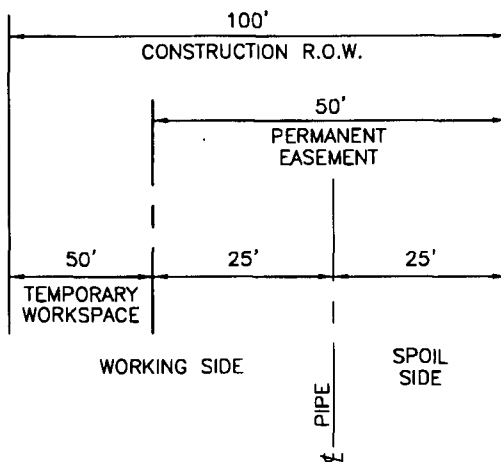
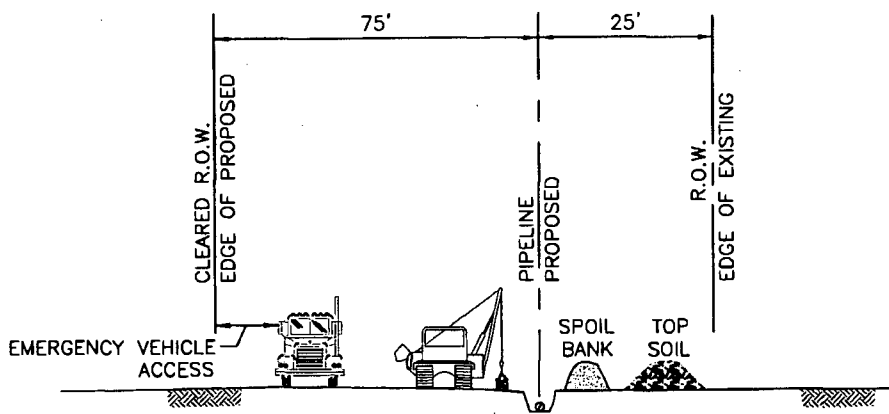

1. TYPE CP-2 CATHODIC PROTECTION TEST STATION SHALL BE INSTALLED AT FOREIGN PIPELINE CROSSINGS, WHEN INDICATED ON THE ALIGNMENT SHEETS.
2. MAINTAIN 24" MINIMUM CLEARANCE WHEN CROSSING OVER OR UNDER FOREIGN PIPELINES.
3. 6" PIPELINE TO BE PLACED ABOVE, IF FOREIGN PIPELINE OR UTILITY IS BURIED AT DEPTH SUCH THAT 24" SEPARATION AND MINIMUM 48" COVER IS MAINTAINED OVER 6" LINE, OTHERWISE 6" PIPELINE TO BE PLACED UNDER FOREIGN PIPELINE OR UTILITY.
4. SANDBAGS CONSIST OF BURLAP BAGS FILLED WITH EARTH THAT IS FREE OF SHARP ROCKS, TWIGS, AND OTHER OBJECTIONABLE MATERIALS (TOP SOIL SHALL NOT BE USED). USE OF SYNTHETIC MATERIALS FOR BAGS IS NOT ACCEPTABLE.

DWG. NO.		REFERENCE DRAWINGS		ENGINEERING RECORD		 FORTRESS ENGINEERING LTD	 Centurion Pipeline L.P.	
CPL-056-08T-001		ALIGNMENT SHEET		DRN: DQ	07-27-17		UNDERGROUND DETAIL FOREIGN PIPELINE OR UTILITY CROSSING HOCKLEY COUNTY, TEXAS	
CPL-056-08T-002		ALIGNMENT SHEET		CHK: JB	07-27-17			
				APP: DH	07-27-17			
				APP:				
				CLIENT APP:				
NO.	DATE	REVISIONS		BY	CHKD.	APP.	DATE	
0	08-22-17	IFC - (MGP TO MALLET CONN.)		D	JEN	PH		
				CLIENT PROJECT NO.		DWG. NO.		DEPT: CIVIL
				17037		CPL-056T-11-005		SCALE: NONE
				CENTURION AFE NO.				REV. 0
				1207789				

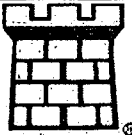

NOTES:

1. CONSTRUCTION RIGHT-OF-WAY WILL TYPICALLY BE 100 FEET WIDE, CONSISTING OF 50 FEET OF PERMANENT EASEMENT AND 50 FEET OF TEMPORARY WORKSPACE. FURTHER, ADDITIONAL TEMPORARY WORKSPACE (ATWS) WILL BE NECESSARY FOR HORIZONTAL DIRECTIONAL DRILL INSTALLATIONS AND AT ROAD, RAIL AND RIVER CROSSINGS AND OTHER SPECIAL CIRCUMSTANCES, AS REQUIRED. CERTAIN SITUATIONS MAY REQUIRE A NARROWER WIDTH.
2. LEAVE GAPS IN SPOIL PILES AT KNOWN DRAINAGE LOCATIONS, UTILIZING PROPERLY INSTALLED BEST MANAGEMENT PRACTICES TO PREVENT SEDIMENTATION. UPLAND SOILS SHALL NOT BE PLACED IN CANALS OR WETLANDS.
3. DITCH LINE TOPSOIL IN ALL JURISDICTIONAL WETLANDS, JURISDICTIONAL CROSSINGS, AND IN ALL AGRICULTURAL AREAS.
4. SEE ALIGNMENT SHEETS FOR ACTUAL ROW CONFIGURATION.

DWG. NO.		REFERENCE DRAWINGS		ENGINEERING RECORD				 FORTRESS ENGINEERING LTD	 Centurion Pipeline L.P.		
PROPERTY SKETCH		PROPOSED 50' P/L EASEMENT		DRN:	DQ	08-08-17	DETAIL - D 100' PIPELINE RIGHT-OF-WAY RIGHT - WORKING SIDE				
CPL-056-06T-002		ALIGNMENT SHEET		CHK:	JSN	08-08-17				DWG. NO. CPL-056T-11-006	
				APP:	DM	08-08-17	DEPT: PIPELINE SCALE: NONE				
				APP:			REV.				
				CLIENT APP:			0				
NO.	DATE	REVISIONS			BY	CKD.	APP.	DATE	CENTURION AFE NO.		
0	08-22-17	IFC - (MGP TO MALLETT CONN.)			D	SN	AL				

TOTAL ARO PIPE LENGTH: 202 ft

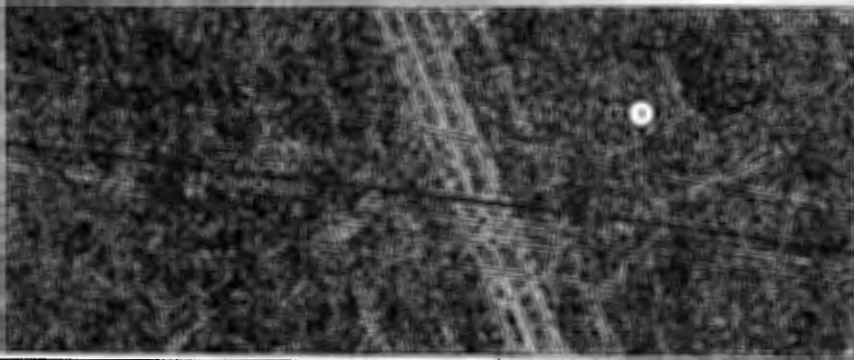

TOTAL ARO PIPE LENGTH: 315 ft

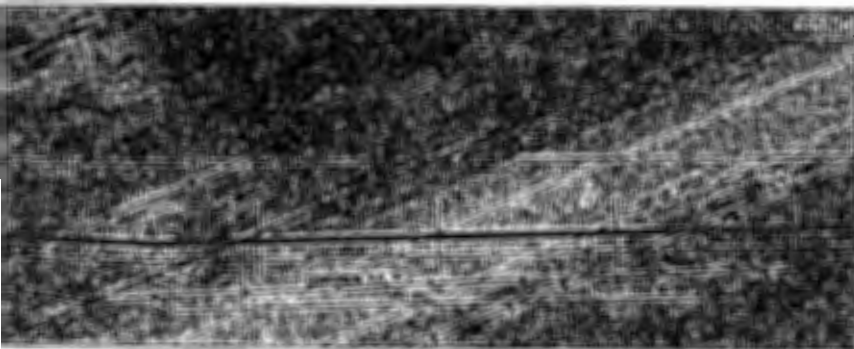

GENERAL NOTE:

1. BORE HOLE LOCATIONS ARE ESTIMATED BASED ON OFFSET FROM ROAD/DITCH TOPOGRAPHY AND TO BE CONFIRMED BY BORING CONTRACTOR.
2. 20 ft CLEARANCE REQUIRED FOR BORING.

NO.	DATE	REVISIONS	BY	CK'D.	APP.	DATE	CLIENT APP.	CLIENT DATE	ENGINEERING RECORD
0	08-22-17	ISSUED FOR CONSTRUCTION - (MCP TO MALLET CONNECTION)	JP	JL	AV				DRN: DG 08-08-17 CTR: JN 08-08-17 APP: DM 08-08-17 CLIENT APP:
									DO NOT SCALE DWG. USE DIMENSIONS ONLY



FORTRESS ENGINEERING L.P.
CLIENT PROJECT NO. 17037

Centurion Pipeline L.P.

**SLAUGHTER GAS PLANT TO MALLET STATION
BORE HOLE DETAIL
WILD CAT ROAD & HIGHWAY 301 CROSSING
HOCKLEY COUNTY, TEXAS**

CENTURION AFE NO. 1207769

DWG. NO. CPL-0561-11-007

DEPTH PIPELINE SHEET: 1 OF 1

REV. 0

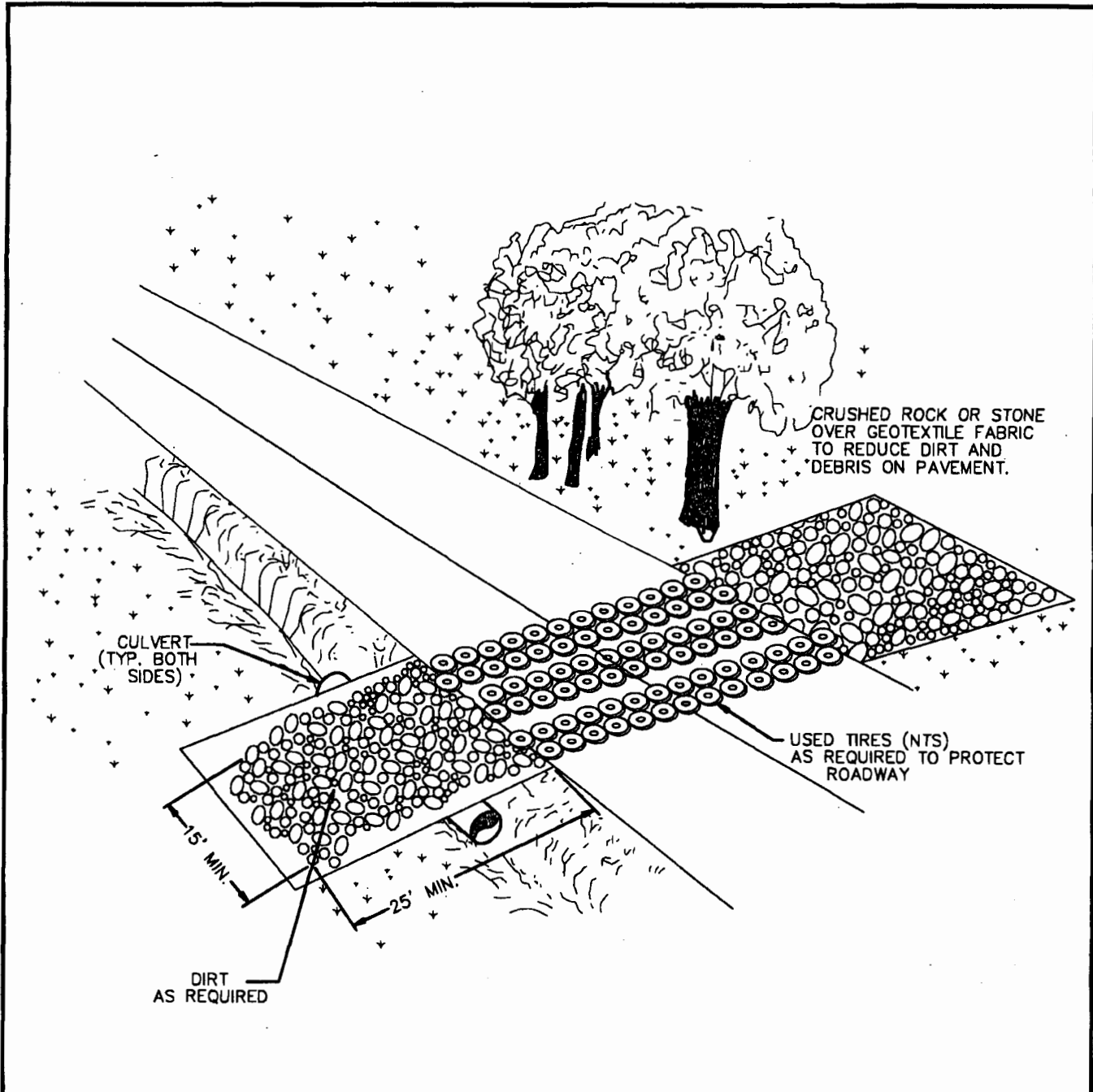

For Information

DWG. NO.		REFERENCE DRAWINGS		ENGINEERING RECORD				 Centurion Pipeline L.P.				
				DRN:	JP	7/14/14	UNDERGROUND DETAIL FOREIGN PIPELINE OR UTILITY CROSSING					
				CHK:	AB	7/21/14						
				APP:	RLT							
				APP:								
				CLIENT APP:								
NO.	DATE	REVISIONS		BY	CKD.	APP.	DATE	CLIENT PROJECT NO.	DWG. NO.	DEPT: CIVIL	REV.	
									CPL-000-0518	SCALE: NONE	0	
								CENTURION AFE NO.				

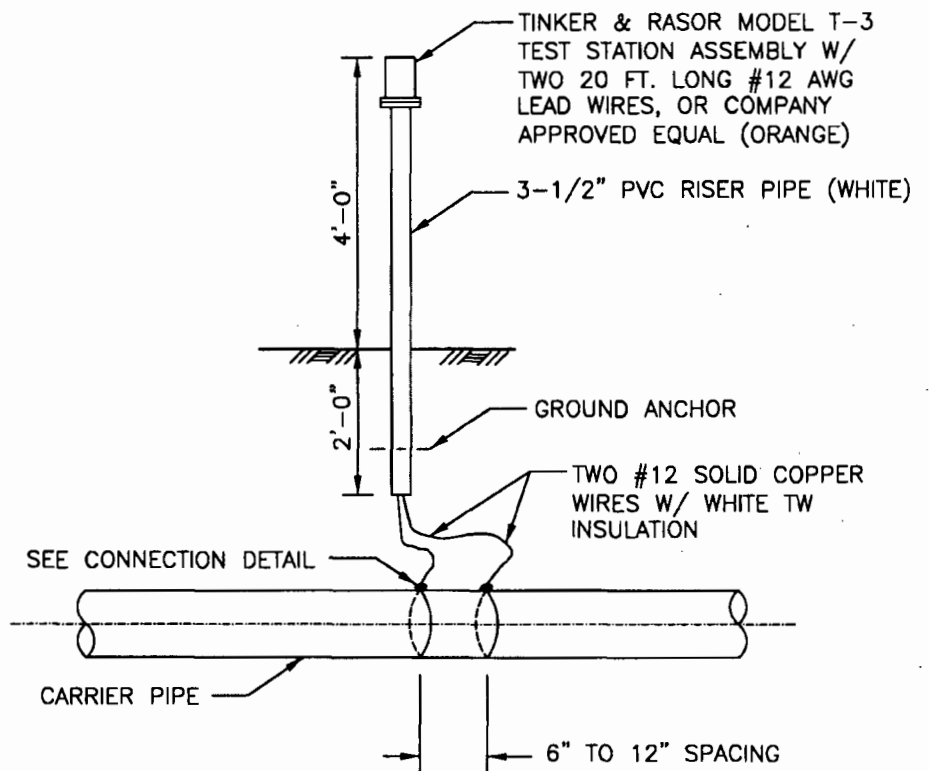

NOTES:

1. INSTALL TEST STATIONS AS INDICATED ON ALIGNMENT SHEETS.
2. ALL WIRE CONNECTIONS TO CARRIER PIPE SHALL BE IN ACCORDANCE WITH STANDARDS.
3. ALL WIRE CONNECTIONS TO CARRIER PIPE SHALL BE COATED IN ACCORDANCE WITH ENTERPRISE STD. 7002 - PROTECTIVE COATINGS - BELOW GROUND STEEL SURFACES - FIELD APPLIED.
4. LOOP AND HITCH LEAD WIRES AROUND PIPE.

For Information

DWG. NO.	REFERENCE DRAWINGS	ENGINEERING RECORD				Centurion Pipeline L.P. DETAIL CATHODIC PROTECTION STANDARD SINGLE POINT TEST STATION TYPE 1				
		DRN.	JP	7/14/14						
		CHK.	AB	7/21/14						
		APP.	RLT							
		APP.								
NO.	DATE	REVISIONS	BY	CKD.	APP.	DATE	CLIENT PROJECT NO.	DWG. NO.	DEPT: CIVIL	REV.
							CENTURION AFE NO.	CPL-000-556	SCALE: NONE	0

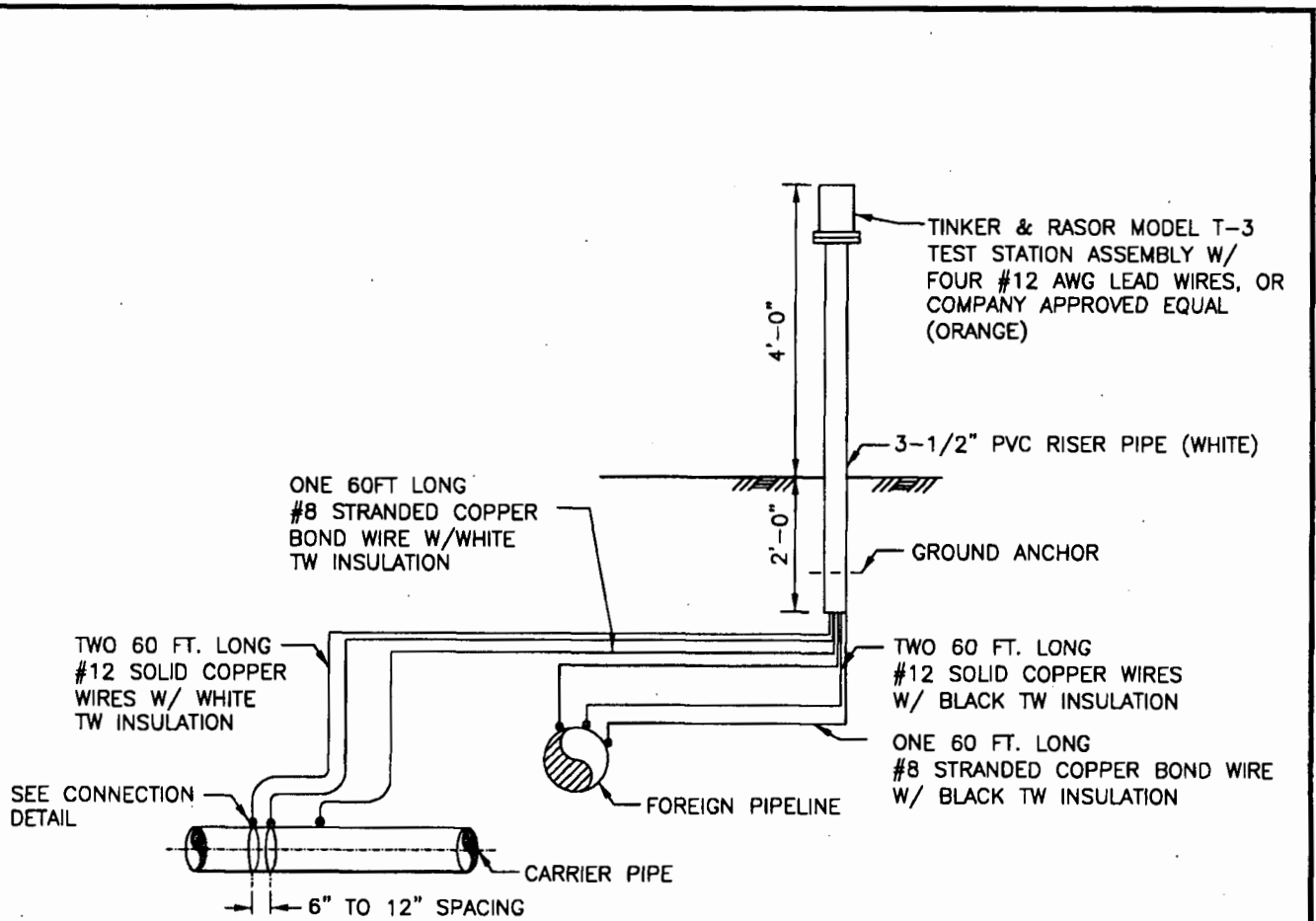

NOTES:

1. INSTALL TEST STATIONS AS INDICATED ON ALIGNMENT SHEETS AND AS DESIGNATED BY COMPANY.
2. ALL WIRE CONNECTIONS TO CARRIER PIPE SHALL BE MADE IN ACCORDANCE WITH ENTERPRISE CP7 - ATTACHING CATHODIC PROTECTION CONDUCTORS.
3. ALL WIRE CONNECTIONS TO CARRIER PIPE SHALL BE COATED IN ACCORDANCE WITH STANDARDS.
4. ALL WIRE CONNECTIONS TO FOREIGN PIPELINE SHALL BE AS SPECIFIED BY FOREIGN PIPELINE COMPANY'S AUTHORIZED REPRESENTATIVE.
5. LOOP AND HITCH LEAD WIRES AROUND PIPE.
6. TEST STATION SHALL BE LOCATED AT CLOSEST PROPERTY OR FENCE LINE. IF TEST STATION LOCATION IS OVER 50 FEET FROM THE PIPELINE CROSSING, ATTACH BLACK WIRES TO CARRIER PIPE AT THE TEST STATION LOCATION. WHITE WIRES TO FOREIGN PIPELINE SHALL ALWAYS BE ATTACHED AT PIPELINE CROSSING.
7. FOR TEST STATIONS REQUIRING TEST LEAD WIRES LONGER THAN 60 FT., ADDITIONAL WIRE SHALL BE PROVIDED. NO SPLICES WILL BE ALLOWED.
8. LEAVE #8 WIRES LOOSE IN TEST HEAD WITH TAPE.

For Information

<small>DWG. NO.</small>	<small>REFERENCE DRAWINGS</small>	<small>ENGINEERING RECORD</small>				Centurion Pipeline L.P. DETAIL CATHODIC PROTECTION FOREIGN PIPELINE CROSSING TEST STN. TYPE 2				
		<small>DRN:</small>	JP	7/14/14						
		<small>CHK:</small>	AB	7/21/14						
		<small>APP:</small>	RLT							
		<small>CLIENT APP:</small>								
<small>NO.</small>	<small>DATE</small>	<small>REVISIONS</small>	<small>BY</small>	<small>CKD.</small>	<small>APP.</small>	<small>DATE</small>	<small>CLIENT PROJECT NO.</small>	<small>DWG. NO.</small>	<small>DEPT: CIVL</small>	<small>REV.</small>
								CPL-000-557	SCALE: NONE	0

HOCKLEY COUNTY, TEXAS
PRELIMINARY SKETCH

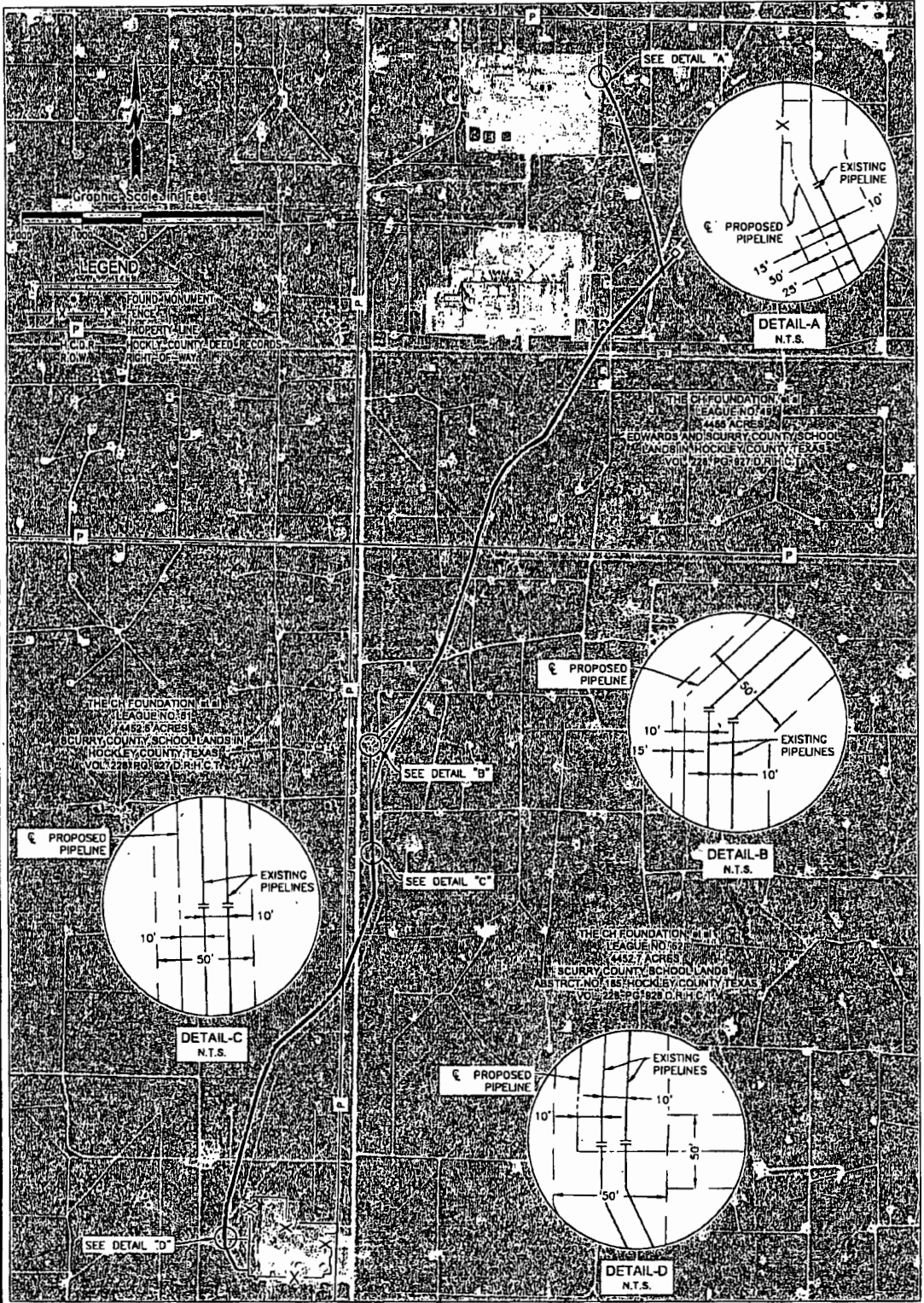

PIPELINE EASEMENT: 22250 LF., (1348.5 ROADS)

												OXY PIPELINE		
												SGP TO Mallet PROPOSED 50' PIPELINE EASEMENT HOCKLEY COUNTY, TEXAS		
				ISSUED			JRC		7/28/17		LCD		LCD	
				ISSUED			PLT		6/28/17		LCD		LCD	
REV			DESCRIPTION			BY		DATE		CHK'D		APPR.		
										SCALE		1"=30'		
										DATE		06/28/17		
										DRAWN		PLT		
										CHK'D		LCD		
										APPRVD		LCD		
										THE C.H. FOUNDATION		REVISION		
										A		SHEET 1 OF 1		

S:\AFS\Survey\Projects\OXY\017887_SGP_to_Mallet\2_Prelim\6_Survey\Dwg\PROPERTY SKETCH.dwg

BEFORE THE HONORABLE BOARD OF COUNTY COMMISSIONERS
HOCKLEY COUNTY, TEXAS

IN THE MATTER OF THE APPLICATION OF CENTURION PIPELINE LP FOR
AUTHORITY TO USE A PART OF THE PUBLIC ROADS OF HOCKLEY COUNTY, TEXAS

ORDER

This cause coming on to be upon the petition of CENTURION PIPELINE LP, hereinafter referred to as "Petitioner". The Board finds that in order that Petitioner may carry out its corporate objects and powers, it is necessary for it to lay, construct, operate and maintain pipelines across certain county roads situated in Hockley County, Texas, as set forth in the Petitioner's application filed herein.

THEREFORE, IT IS HEREBY ORDERED that, subject to the conditions herein after set forth, said Petitioner, CENTURION PIPELINE LP, is hereby granted permission and authority to lay, construct, operate and maintain pipelines across certain county roads at the locations set forth in Exhibits "A" and "B" attached to the application of Petitioner herein, which Exhibits "A" and "B" and application are hereby made a part of this order as fully as if set out in length herein provided.

1. The Petitioner shall, in constructing said pipelines undercrossings cause the very minimum of inconvenience and obstruction of public travel along said roads, and, further, shall operate and maintain said pipelines undercrossings in a manner so as not to inconvenience, endanger or obstruct public travel along said roads.
2. Upon the completion of each pipelines undercrossing constructed hereunder Petitioner shall immediately backfill, re-construct and replace the portions of the roads across which said pipelines are laid and constructed so that such roads shall be in equally as good a condition as prior to such construction.
3. So long as said pipelines are maintained and operated under said roads Petitioner shall be responsible for doing any work which, due to the existence of said pipelines undercrossings, needs to be done on said roads at the location thereof, all in order to maintain said roads, at such points, in a condition equal to other portions of said county roads.
4. Should Petitioner remove said pipelines from any of said roads, it will replace and recondition the road concerned, at the location of said removal, in substantially the same condition as it was prior to such removal, all liability of Petitioner for the maintenance and reconditioning of such roads shall cease as soon after such removal as the COUNTY OF HOCKLEY has approved the maintenance and reconditioning work done by Petitioner.
5. Petitioner agrees that if at any time the County of Hockley shall deem it necessary to make any improvements or changes on all of or any part of the right of way of the county roads which affect the Utility as located under this order, then and in such event, the Petitioner or his Assignee shall make such reasonable changes of its facilities located within such right of way as may be deemed necessary, such work to be done without cost to Hockley County, Texas.
6. The construction or laying of said pipelines by Petitioner hereunder shall be considered and shall constitute and acceptance of this order and of all of the terms and conditions herein set forth.
7. Petitioner agrees that if at any time the County of Hockley deems it necessary that these crossings be encased in accordance with the then existing State Highway specifications, Petitioner agrees to do so at its own expense.

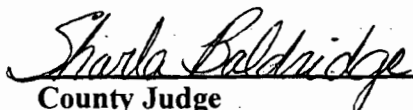
County Judge

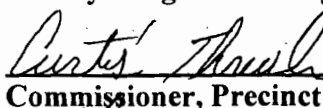
Commissioner, Precinct No. 1

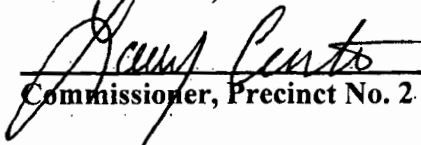
Commissioner, Precinct No. 2

10-16-2017
Date

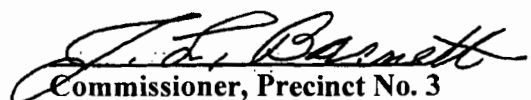
Commissioner, Precinct No. 3

Commissioner, Precinct No. 4

There being no further business to come before the Court, the Judge declared
Court adjourned, subject to call.

The foregoing Minutes of a Commissioners' Court meeting held on the 16th
day of October, A. D. 2017, was examined by me and approved.

Curtis Thrash
Commissioner, Precinct No. 1

J. L. Bennett
Commissioner Precinct No. 3

Randy Cuts
Commissioner, Precinct No. 2

Tommy Clewley
Commissioner Precinct No. 4

Shirley Baldrige
County Judge

Irene Gumula by Jamie Salazar
IRENE GUMULA, County Clerk, and
Ex-Officio Clerk of Commissioners' Court
Hockley County, Texas

